

## THE POSSIBILITIES OF BIODIVERSITY MONITORING BASED ON HUNGARIAN LIGHT TRAP NETWORKS

GIMESI, L.<sup>1\*</sup> – HUFNAGEL, L.<sup>2</sup>

<sup>1</sup>*University of Pécs, Faculty of Natural Sciences, Department of Informatics  
H-7624 Pécs, 6 Ifjútság Road, Hungary  
(phone: +36-72-503-600; fax: +36-72-503-697)*

<sup>2</sup>*”Adaptation to Climate Change” Research Group, Hungarian Academy of Sciences  
H-1118 Budapest, Villányi út 29-43., Hungary*

*\*Corresponding author  
e-mail: gimesi@ttk.pte.hu*

(Received 16<sup>th</sup> November 2010 ; accepted 19<sup>th</sup> November 2010)

**Abstract** Our method is presented with displaying time series, consisting of the daily amount of precipitation of 100 years, which has meant a separate challenge, as the precipitation data shows significant deviations. By nowadays, mankind has changed its environment to such an extent that it has a significant effect on other species as well. The Lepidoptera data series of the National Plant Protection and Forestry Light Trap Network can be used to justify this. This network has a national coverage, a large number of collected Lepidoptera, and an available, long data series of several years. For obtaining information from these data, the setting up of an easy to manage database is necessary. Furthermore, it is important to represent our data and our results in an easily analysable and expressive way. In this article the setting up of the database is introduced, together with the presentation of a three dimensional visualization method, which depicts the long-range and seasonal changes together.

**Keywords:** *biodiversity, monitoring, data mining, Lepidoptera*

### Introduction

The spreading and the structure of ecological associations significantly depend on environmental factors and resources. This is called ecological niche, which can be perceived as part of an n dimensional space that is used by the given population (n dimension means the n number of different environmental effects and resources).

There is no opportunity on an examination of population dynamics to investigate all (n) environmental factors. Therefore we only looked for relationships between a few relevant environmental parameters and the data collected by monitoring the communities. In view of these correlations we attempted to draw conclusions about the future state of the population.

The size and the structure of populations are influenced by several factors: agriculture, urbanization, climate, soil, vegetation, solar radiation, etc. However, these effects are not independent from each other. Climate change has an effect on each component. Thus, environmental effects (biotic and abiotic), cannot be examined independently from each other. That is, no such ideal circumstances can be created, where it could be investigated for example how the population is effected by temperature changes, since it has an effect on other influential environmental factors as well, which can have an effect on the investigated population. The investigation is further complicated by the fact that climate is not the only thing having an effect on the population and its surroundings. Primarily human activity should be mentioned here.

One of the big problems of these times is that the data available for us are growing at an incredible pace. Filtering out important data from the databases is getting to be an increasing problem.

The aim of our work is to create a database from the Lepidoptera data of the light trap network, which assures the availability of data for the purpose of writing this article and further researches in an easily manageable form. Besides this we have introduced a three-dimensional depicting method in this article, which presents time series figures in an expressive way.

A Visual-Basic program has been made for data processing, evaluating and visualizing the results. We chose this programming language primarily because it can easily be set up for the direct use of Excel and Access files. These programs are suitable for the graphical visualization of long time series with the help of Autocad and ArcGIS graphical programs.

## Review of literature

The most widespread collection method of Lepidoptera flying at night is light trapping. This method was first employed following the experiments of Williams (1935). Light traps have been used since 1940 in Hungary. In 1952 the construction of an internationally unique trap network began (Jermy, 1961; Nowinszky, 2003a). By now, the Hungarian light trap system has been equipped uniformly with Jermy type light traps.

Those light traps that have been operating for a long time uninterrupted, in the same place are the most suitable for population dynamics investigation (Nowinszky, 2003b).

It is practical to use all the light trap data because of the effects of different abiotic factors. This way it is achievable that the effects appearing in different collection places and modifying the number of collections neutralize each other (Nowinszky, 2003b).

The longest possible time series (daily data series) is needed to define the changes in a data series and its tendencies in the most reliable way. It should cover the largest possible geographical area and data collection should be carried out with the same method all along. The data series of the National Plant Protection and Forestry Light Trap Network is the most adequate for these conditions (Hufnagel et al., 2008).

Large quantity data coming from different sources can be processed with methods of data mining. As a first step data warehouses are created from databases (Böhlen, 2003; Fan, 2009; Han and Kambel, 2004; Keim, 2004). This procedure is preprocessing (Kennedy, et al. 1998; Pyle, 1999), during which the automatically detectable defective data are removed. The rest of the defective data can be filtered out only with human assistance, in an interactive way (Han and Kambel, 2004).

With the joining of databases a data structure is created, which ensures data access according to several points of view. The most suitable structure for this is an n-dimensional data cube (Euler, 2005; Gray et al., 1997).

The moving average method can be used for filtering out extremes appearing in databases and for decreasing the fluctuations in data series (Heuvelink and Webster, 2001). It smoothes the data series at the same time (Han and Kambel, 2004).

Image visualization is closer to human thinking than large tables containing numerical data, which, though, provide exact information, but are difficult to handle and they are not suitable to present correlations (Gimesi, 2004) either. When analysing

calculation results, it can be helpful if the data is presented in an easily interpretable, graphical form.

We used three-dimensional figures for the presentation of long time series, where the yearly and seasonal changes could be seen well – these are outlined by Gimesi (2009). A similar depicting method was used by Mulligan (1998) for the demonstration of the seasonal changes of vegetation. He remarked that the method is able to demonstrate both short- and long-range tendencies. For the demonstration of Lepidoptera data, three-dimensional figures were also used by Marchiori and Romanowski (2006).

Diversity indices are numerical functions defined on sets of species frequency or species occurrence probability (Izsák, 2001). So the diversity of a biozooenosis – in an ecological sense – is some kind of a function of the number and abundance of species.

Biological diversity primarily means the variousness of species regarding a given area and a given period. Species, genus or genetic diversities can be studied, such as epidemiologic or population diversities (Izsák, 1994; Izsák and Juhász-Nagy, 1984).

However, diversity indices do not provide information about the spatial position of entities, which can characterize the community at least as much as the number of species or the diversity (Menhinick, 1962).

In statistical ecology numerous functions are applied as diversity indices (Dewar and Porté 2008; Izsák, 2001; Mishra et al., 2009; Sipkay et al., 2005; Tóthmérész, 1997). Different diversity indices described in the ecological literature present the diversity of a given species community from different points of view. It is general experience that the diversity of numerous fauna and flora communities measured by different indices show significant positive correlation. The main reason for this is the high sensibility of indices to the change of population with the largest number of entities. Indices depend on the size of the sample, though to different extent (Ibáñez et al., 1995).

Numerous methods have been worked out to characterize diversity, which can be assorted as follows, according to Tóthmérész (2001):

- Number of species,
- Diversity indices,
- Classical diversity statistics,
- Scale-pending characterization of diversity,
- Mosaicity, the role of patterns ( $\beta$ -diversity),
- Space-series analysis.

Shannon diversity index is the most commonly used in ecological literature (e.g.: Arnan et al., 2009; Balog et al., 2008; Chefaoui and Lobo, 2008; Kevan, 1999; Skalskia and Pośpiech, 2006), therefore we also investigated the distribution of collected Lepidoptera with the help of this one.

**Table 1.** Trap statistics (highlighted traps worked for the longest time)

Trap Code	Date		Operation Time [months]	Number of Individuals	Number of Species	Name of Trap
	Start	End				
1	Nov. 1961.	Dec. 1975.	139	63948	572	Budakeszi
2	Jun. 1961.	July. 1991.	302	602476	798	Makkoshotyka
3	Jun. 1961.	Dec. 2006.	441	285752	776	Felsőtárkány
4	Apr. 1962.	Dec. 2006.	421	291694	677	Gerla-Gyula
5	Jan. 1962.	Apr. 1976.	147	29852	60	Kunfehértó
6	Apr. 1965.	Oct. 1990.	185	134303	588	Farkasgyepű
7	Jun. 1961.	Dec. 2006.	364	102903	662	M.Háza,M.Almás
8	Mar. 1962.	Nov. 2006.	417	298604	686	Répáshuta
9	Feb. 1962.	Oct. 2006.	393	193967	770	Sopron
10	Aug. 1967.	Jun. 1973.	45	11267	416	Szakonyfalu
11	Jan. 1961.	Dec. 2006.	354	301795	697	Szentpéterfölde
12	Mar. 1962.	Feb. 1977.	153	39242	520	Szombathely
13	Jun. 1961.	Dec. 2006.	403	325227	689	Tolna
14	Mar. 1962.	Oct. 2006.	445	715915	696	Tompa
15	Feb. 1962.	Nov. 2006.	446	476072	765	Várgesztes
16	Jun. 1969.	Aug. 1990.	149	25183	479	Gyulaj-Kocsola
17	Aug. 1969.	Dec. 2006.	334	175334	698	Erdősmecske
18	Aug. 1969.	Aug. 2003.	85	48671	552	Kömörő
19	Aug. 1969.	Aug. 1975.	48	578	33	Kökút
20	Sept. 1969.	Jun. 1974.	28	1125	30	Alsókövesd
21	Mar. 1970.	Aug. 1975.	45	1656	30	Zalaerdőd
22	July. 1972.	Aug. 1995.	204	82770	621	Piliscsaba
23	May. 1978.	Nov. 2006.	186	200144	638	Gilvánfa-Sumony
24	Sept. 1977.	Dec. 2006.	243	557826	638	Kapuvár
25	Aug. 1976.	Sept. 1995.	152	87831	458	Karcag-Apavára
26	July. 1976.	Dec. 2006.	253	326855	656	Bugac
27	July. 1976.	Nov. 2006.	253	183090	672	Nagyrákos-Szala
28	Jun. 1976.	Oct. 2003.	147	68158	538	Szulok
29	May. 1976.	Aug. 1985.	72	41544	526	Zalaszántó-Supr
30	Sept. 1975.	Nov. 2006.	215	183190	675	Sárvár-Baj-Acsád
31	Mar. 1988.	Oct. 1990.	23	6080	62	Bejcgertyános
32	1977. Apr.	July. 2006.	268	161841	618	Sasrét
33	Sept. 1979.	Nov. 2000.	188	190769	548	Jánkmajtis
34	May. 1990.	Nov. 2006.	154	151071	560	Diósjenő
35	Apr. 1992.	Jun. 1995.	14	1785	141	Nagylózs
36	Mar. 1992.	Oct. 1998.	38	19153	394	Telkibánya
37	Sept. 1975.	Dec. 2006.	141	108785	493	Hőgyész-Tamási
38	Mar. 1981.	July. 1981.	5	1183	159	Ivác
40	Mar. 1977.	Sept. 2003.	128	181664	568	Ásotthalom
41	May. 1993.	May. 1993.	1	39	18	Gödöllő
42	July. 1976.	July. 1979.	26	3094	301	Nádasd
43	Jun. 1977.	Aug. 1977.	3	457	54	Albertírsa
52	Sept. 1991.	Nov. 2006.	133	204087	702	Bakonybél-Somh
53	May. 1994.	Dec. 1995.	13	9468	313	Mosonmagyaróár
54	Dec. 1993.	Oct. 1995.	15	4285	195	Ásványráró
55	Mar. 1995.	May. 2001.	49	24170	368	Barcs-Krigóc
56	Apr. 1993.	Oct. 2006.	109	117965	510	Egyházaskesző
57	Apr. 1996.	Oct. 2006.	48	53304	434	Kecskemét
58	Apr. 1996.	Nov. 2003.	57	58244	517	Pilismarót
59	Apr. 1995.	Dec. 2006.	93	136481	459	Püspökladány
60	Mar. 1999.	Nov. 2006.	71	29617	466	Kemencepatak
61	Apr. 1999.	Sept. 1999.	6	6322	195	Maroslele
62	Mar. 2005.	Aug. 2006.	12	15209	289	Csöprönd
63	Mar. 2005.	Sept. 2006.	16	21667	335	Szentendre
64	Apr. 2005.	Dec. 2006.	17	35804	365	Vámosatya

## Materials and methods

In the course of our work we used the National Plant Protection and Forestry Light Trap Network, the first light traps of which were installed in 1961 (Szontagh, 1975).

These traps are operating all year round, except for those days when the temperature does not rise above 0 °C, or when the area is covered by snow (Nowinszky, 2003a). We received the data of the National Plant Protection and Forestry Light Trap Network in dBase format. Our object was to create a database out of these hardly processable data that allows access to the data easily, in a general format. This way we have created a database essential for further researches.

The data of the National Plant Protection and Forestry Light Trap Network were processed using data-mining methods. As a first step – based on a method well known in the literature (Böhlen, 2003; Fan, 2009; Han and Kambel, 2004; Keim, 2004) – we created a data warehouse out of the available databases. This process included the merge and the filtering of databases (Bogdanova and Georgieva, 2008).

The trap statistics created from the trap data can be seen in *Table 1*. In this table the beginning and the end of the operation are shown, together with the operation time in months, the total number of collected individuals, the number of collected species, and the name of the trap (its geographical position).

### *The merge of databases*

The original (light trap collection) data can be found in separate databases for each trap. The record structure of the original databases can be seen in *Fig. 1*.

*Data*

SORSZ	CSAPDA	K_KOD	A_EV	A_HO	D1	D2	.....	D31	FELV	FIDO	JEL	IDO
:	:	:	:	:	:	:	.....	:	:	:	:	:

**Figure 1.** The record structure of the original databases

The following fields can be found in the databases:

- SORSZ (sn) – ordinal number of the measurement
- CSAPDA (trap) – trap code
- K\_KÓD (l\_code) – code of the insect species( Lepidoptera)
- A\_EV (yoh) – year of collection
- A\_HO (moh) – month of collection
- D1-D30 – number of individuals collected daily
- FELV (rec) – name of the data recorder
- FIDO (torec) – date of recording
- JEL (sign) – sign
- IDO (time) – date of collection

*Fig. 2* presents the record structure of trap and species databases. These are linked to the structure presented in *Fig. 1*.

CS_KOD	CS_NEV	MENT
⋮	⋮	⋮

K_KOD	K_NEV	K_RNEV	KONYV
⋮	⋮	⋮	⋮

**Figure 2.** The record structure of trap and species databases

The following fields can be found in the databases:

- CS\_KOD (trap) – trap code
- CS\_NEV (name) – name of the trap
- MENT – one boolean data
- K\_KOD (species) – species code
- K\_NEV (name) – name of the species
- K\_RNEV (name) – short name
- KONYV (name) – name by book

Fig. 3. demonstrates the relational connections of tables (records) presented in Fig.1, Fig. 2.

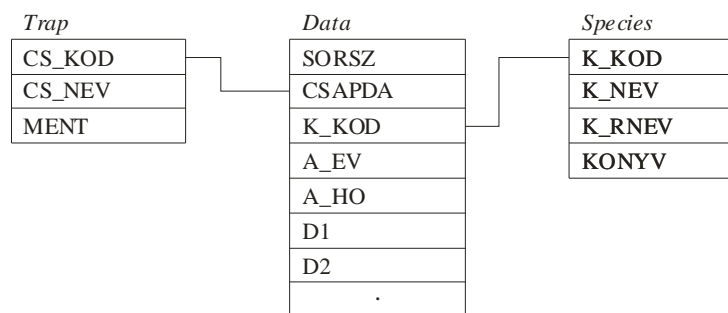
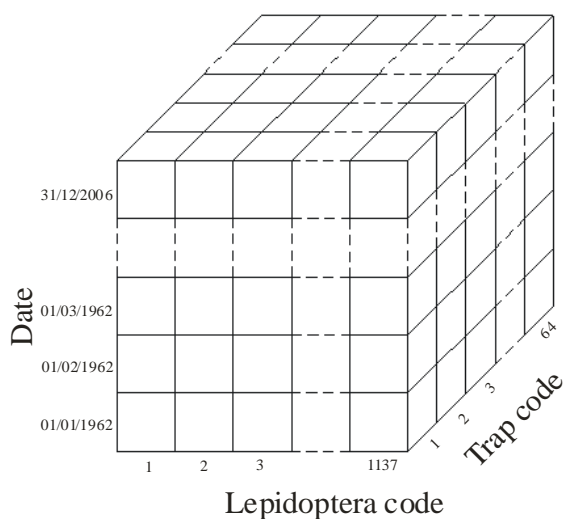

**Figure 3.** The relational connections of data-tables

With the merge of databases we created a data structure that ensures searching by trap code, Lepidoptera code, and date. The most suitable structure for this is the three-dimensional data cube that can be seen in Fig. 4. The dimensions of the cube are: *time*, *trap code*, *species code*. This way one elemental cube contains the number of species collected in a given trap on a definite day.

For the sake of quicker data access and the following graphical depiction we have divided the time dimension into year and day. Therefore we actually used a four-dimensional data cube.

While defining the ordinal number of the day – for the sake of uniformization – years were considered to contain 365 days, i.e. measurements made on 29<sup>th</sup> February were excluded. This did not cause any error, as during the 45-year period of investigation – considering all the traps and species – it meant leaving out altogether 109 individuals.



**Figure 4.** *The data cube*

### ***Data filtering, data cleaning***

During the course of creating the data warehouse we executed an automatically performable filtering, during which:

- incorrect dates coming from data recording mistakes were removed (only the data of the period between 1962 and 2006 were collected, the ordinal number of months had to be between 1 and 12, and the number of days had to correspond with the value belonging to the given month),
- those species codes that were not included in the species database have been filtered out,
- doubly recorded data were deleted.

The filtering out of other defective data can be executed in an automatic way only to a limited extent. In the rest of the cases an interactive (requiring human assistance) filtering can be carried out (Han and Kambel, 2004). The visualization method recited in this article is suitable for noticing flagrant (widely differing from the environment) data easily (Gimesi, 2008).

### ***Filtering based on trap code***

Those light traps that have been operating in the same place for a long time without interruption are the most suitable for the purpose of investigating population dynamics (Nowinszky, 2003b). Accordingly, we chose from the database those traps that have worked for the longest time, mindful of having data of the highest possible number of days in the examined period. We have chosen those 9 traps that worked for the longest time between 1962 and 2006. The data of these are marked with highlighting in *Table 1*.

For the sake of further processing we distinguished between the cases when a trap did not operate and when it did not collect any specimen of the given species. A trap was considered not operating when no collection happened on a given day regarding all species.

The geographical position of the examined traps are demonstrated in *Fig. 5*. In this figure green (darker) rings indicate those settlements where the chosen traps can be found.



**Figure 5.** The regional distribution of the examined light traps

#### *Filtering based on species code*

From this point on only those species data were used where there was collection of at least one specimen every year in the examined period (1962-2006), considering all the traps. After filtering, altogether 281 species were left in the database.

After finishing data cleaning and data filtering the Lepidoptera database contained the data of 9 traps, 281 species, which altogether meant 4,020,614 records. The structure of the database is shown in Fig. 6.

#### *Lepidoptera database*

EV	NAP	CSAPDA	FAJ	DB
:	:	:	:	:

**Figure 6.** The final structure of the Lepidoptera database

The following fields could be found in the database:

EV (year) – year

NAP (day) – the ordinal number of the day within the year

CSAPDA (trap) – trap code

FAJ (species) – species code

DB – the number of individuals of the species collected on the given day by the given trap

#### *Merging the trap data*

For the sake of decreasing the different abiotic factors and the effects modifying the number of collections happening in different collection places, it is practical to use the data of the greatest possible number of light-tarps (Nowinszky, 2003b). For the creation



of a national time series the data of the traps found in different places had to be merged by species. This is the so called data reducing method (Moon and Kim, 2007), that was carried out by a moving-average calculation. The method of moving-average is suitable for filtering out the extremes occurring in the daily data and to decrease the fluctuations in the data series (Heuvelink and Webster, 2001). This method is also smoothing the time series (Han and Kambel, 2004).

During the moving-average calculations we used the average of 9 days' (moving-average of 9th grade). We chose number 9, because it corresponded to the number of traps. *Fig. 7* demonstrates the window-method that we used to calculate the average, but with fictive data. The figure shows the calculation of the merged data of a given species. Days can be found in the vertical direction, and traps in the horizontal one. "-1" in a cell indicates that the trap did not operate on the given day. In such case, when calculating the average, the content of the cell is not added to the sum and the value of the divisor is not increased either.

		Traps								
Days		0	3	2	0	-1	-1	2	0	0
		2	4	0	-1	2	1	4	3	1
		-1	0	1	-1	5	1	0	5	4
		1	-1	2	0	1	0	3	-1	2
		0	-1	5	2	-1	5	0	4	1
		0	5	1	3	0	2	-1	5	0
		1	0	4	-1	5	4	0	2	3
		-1	-1	2	0	5	1	5	-1	2
		-1	3	0	3	-1	2	4	0	-1

**Figure 7.** The window used for average calculation

The following formula was used for the calculation of average:

$$\frac{1}{n} \sum_{i=k}^{k+8} \sum_{j=1}^9 d_{i,j} \quad k = 1 \dots 16417$$

,where:

$d_{i,j}$  = the value of the cell (number of individuals), where i is the ordinal number of the trap, j is the ordinal number of the day (cells containing 1 are not calculated!)

n = the number of cells not containing 1

k = the first day of the window

The maximum value of k is the number of days between 1<sup>st</sup> January 1962 and 31<sup>st</sup> December 2002, minus 8.

After the calculation of average the data structure outlined in *Fig. 8* was presented, where the rows of the table show the years and the ordinal number of the day within the year (16425 rows), and the columns show the species code (281 columns).

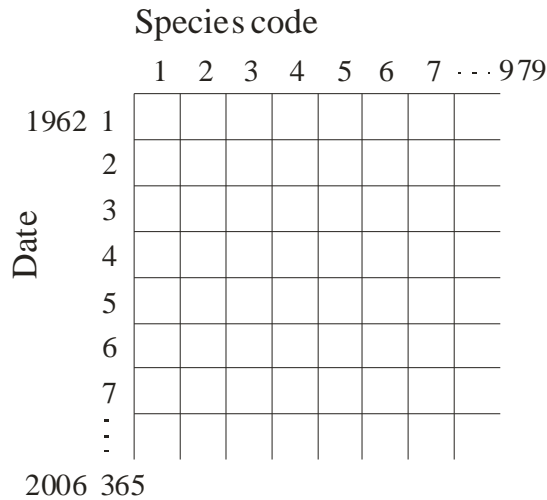

**Figure 8.** The Lepidoptera data table after the average calculation

We made a program using Visual Basic language for the creation of the Lepidoptera data warehouse, for the data filtering and for further data processing.

### Results

Biological diversity means primarily the diversity of species concerning a given area and a given period of time. For the characterization of diversity we used the number of individuals, the number of species, and the Shannon diversity index.

### Time series of aggregate collection

The time series of the number of Lepidoptera collected between 1962 and 2006 is demonstrated in Fig. 9.

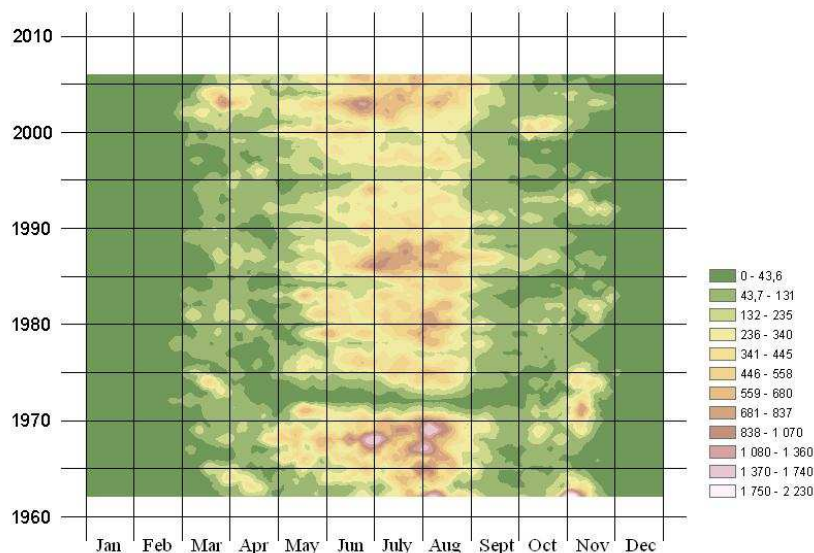

**Figure 9.** The three-dimensional time series figure of the number of individuals based on the Lepidoptera data

It can be seen in the figure that the maximum of the number of individuals occurs in the middle of summer, but there are smaller peaks at the end of March, at the beginning of April and in November, as well.

In summer a significant increase can be observed in the number of individuals, which shows up every 15-20 years.

A remarkable anomaly can be observed in this figure and also in further time series figures in 1972 and 1973. The reason for this is that the definition of Lepidoptera was less accurate in this period.

### *Number of species (taxon)*

One of the most important diversity indices is the number of species (Tóthmérész, 2002), the measure of which depends on the number of entities collected and the attraction zone of the traps. Its drawback is that it does not make a difference between populous species and those that are represented by one or a few entities and moreover, it is territory dependent.

*Fig. 10* shows the distribution of the number of collected species. There are fractions in it as well, because the figure was made by interpolation.

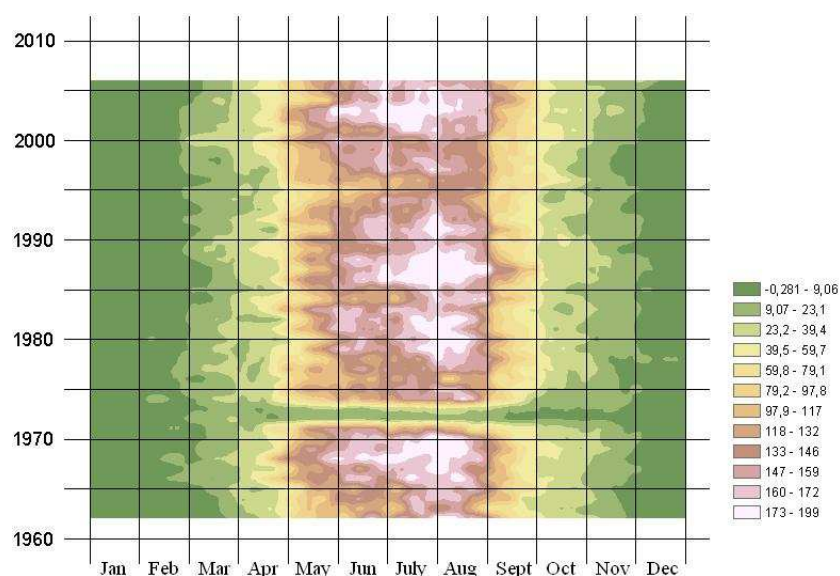

**Figure 10.** *The three-dimensional time series figure of the number of species based on the Lepidoptera data*

The time series of the number of species shows a smoother picture than that of the number of individuals. However, it can be observed here as well that there are periods (years) when the number of species is significantly higher compared to the neighbouring years.

In the literature Shannon index is used the most commonly for the characterization of diversity, therefore we have also used this for the analysis of our data.

This index is sensitive to the changes of rare species, that is its value decreases with the increase of the number of individuals of dominant species, but it increases with the

increase of the number of species. The time series of the Shannon index can be seen in *Fig. 11*.

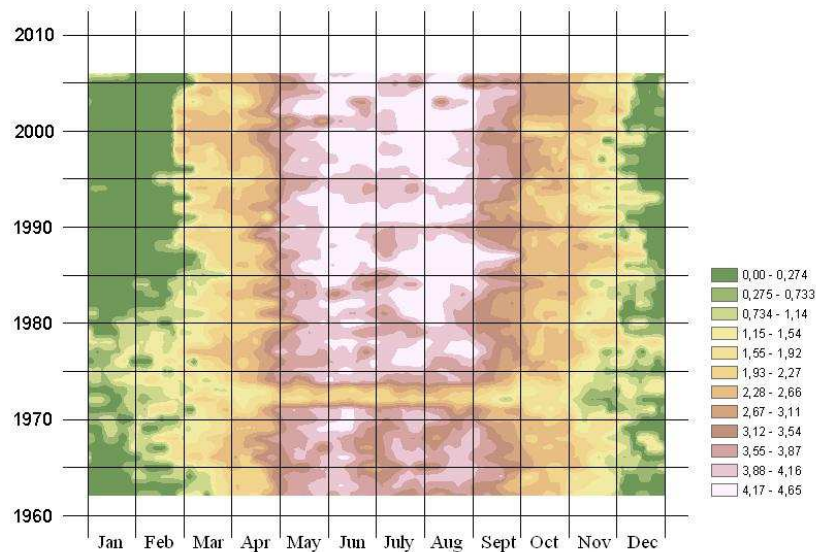

**Figure 11.** The three-dimensional time series figure of the Shannon-Wiener index of *Lepidoptera* data

It can be seen in the figure that the diversity index has maximums in the middle of June and of August. Accordingly, a decrease in diversity can be observed in July.

In the winter period between 1965 and 1980 relatively high diversity values can be seen, in spite of the fact that they cannot be seen either in the time series of the aggregate number of collected individuals (*Fig. 9*), or in that of the species (*Fig. 10*).

It is fully visible in all three figures that the values significantly depend on the season.

A significant anomaly can be noticed in 1972 and in 1973 in the time series figures. A likely reason for this is a personal change at that time, as a consequence of which the definition of *Lepidoptera* was carried out less precisely.

*Fig. 12* shows the numbers of individuals collected daily during the 33- year period, *Fig. 13* show the dispersion as a function of days.

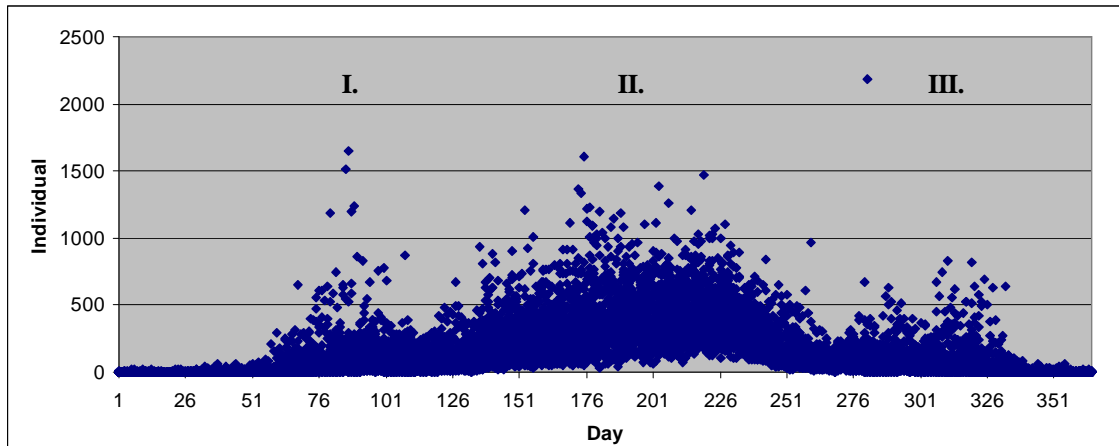

**Figure 12.** The numbers of individuals collected daily based on Lepidoptera data

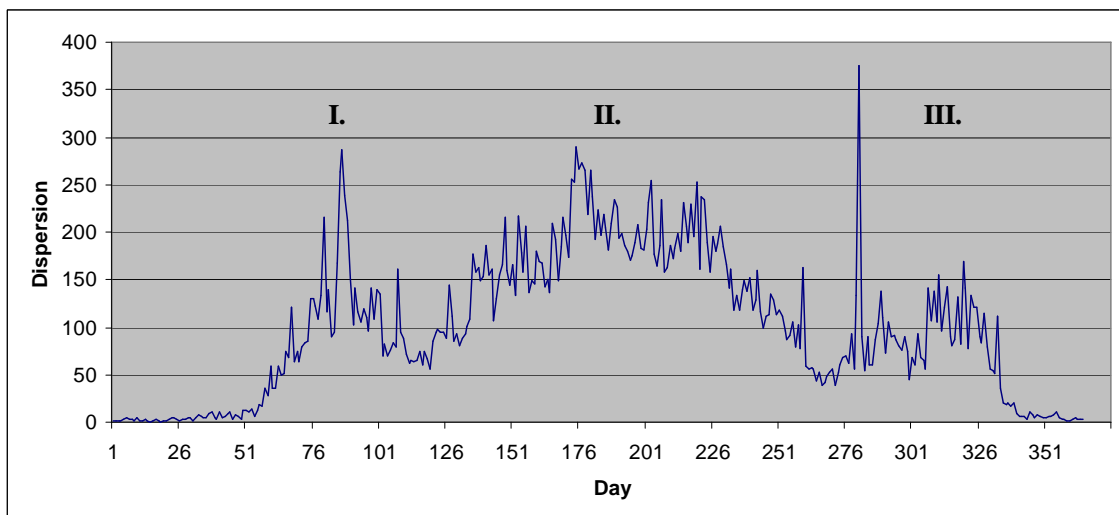

**Figure 13.** Dispersion of the number of individuals collected daily

In *Figure 13* three easily separable stages can be seen: the beginning of spring (I.), summer (II.), and late autumn (III.).

The increase in the numbers of individuals are caused by those dominant species that swarm in those periods.

We have made a list of the dominant species of the three periods, which is shown in *Table 2*. The dominant species appear in a larger ratio during the spring and the autumn period. The reason for this is that in these periods the number of existing species is lower.

Species 42 and 43 are two-generational. 43 is also dominant in the autumn period, which can be seen in the table. Species 172 has two swarms as well, but both of them are in summer.

**Table 2.** *The ratio of the dominant species in the three periods*

Period	Code	Species name	Ratio
Spring	40	Orthosia gothica (Linnaeus, 1758)	7,5 %
	41	Orthosia cruda (Denis & Schiffermüller, 1775)	15,6 %
	42	Eupsilia transversa (Hufnagel, 1766)	9,0 %
	43	Conistra vaccinii (Linnaeus, 1761)	25,2 %
	51	Alsophila aescularia ([Denis & Schiffermüller], 1775)	16,3 %
	449	Orthosia incerta (Hufnagel, 1766)	5,0 %
Summer	172	Ectropis bistortata (Goeze, 1781)	2,8 %
	240	Eilema complana (Linnaeus, 1758)	4,3 %
	398	Athetis furvula (Hübner, 1808)	2,7 %
	411	Paracolax glaucinalis (Denis & Schiffermüller, 1775)	5,2 %
	515	Zanclognatha lunalis (Scopoli, 1763)	4,1 %
	519	Eilema lurideola (Zincken, 1817)	3,7 %
Autumn	43	Conistra vaccinii (Linnaeus, 1761)	3,5 %
	52	Alsophila quadripunctaria (Esper, 1800)	5,8 %
	54	Operophtera brumata (Linnaeus, 1758)	45,7 %
	63	Erannis aurantiaria (Hübner, 1799)	4,0 %
	65	Erannis defoliaria (Clerck, 1759)	16,8 %
	656	Ptilophora plumigera ([Denis & Schiffermüller], 1775)	8,7 %

## Discussion

In this article the data processing of the National Plant Protection and Forestry Light Trap Network was introduced together with a possible visualization method.

The database created is based on the light trap data. It is suitable for utilization in the most important research areas of the national light trapping. These areas were summarized by Szentkirályi (2002). Among them are faunistical, zoogeographical, taxonomical, phytocenological, ethological, phenological, ecological, etc. examinations (Nowinszky, 2003c).

In case of examinations in swarming phenology the number of generations (Nowinszky, 2003b) and the seasonal changes can be determined by the daily depiction of the entity number of species. This method is widespread both in national and in international publications (Ábrahám and Tóth, 1989; Caldas, 1992; Kimura et al., 2008, Mészáros, 1993; Szentkirályi, 1984).

Investigations in population dynamics provide possibility to draw a conclusion about the tendency of change, based on the data of succeeding years (Nowinszky, 2003b). This method has also been used by several publications (Conrad et al., 2006; Leskó et al., 1997; Szentkirályi et al., 1995; Szontagh, 2001; Wolda et al., 1998). These publications depict the annual changes and those within a year separately. By merging these two methods we introduced a three-dimensional method that depicts the seasonal and long-term (annual) changes in one figure. The different time series can be depicted much more expressively with this method (Gimesi, 2008, 2009). A similar method was used by Marchiori & Romanowski (2006) to demonstrate insect collecting time series, and also by Mulligan (1998) to demonstrate the seasonal changes of foliages.

In this article we presented the sorting of those Lepidoptera data into databases which were collected by light traps and a visualization method for that. We did not

examine the reasons considering what environmental effects led to certain changes in the time series.

In the future we are willing to perform different investigations with the help of the compiled database. For example: the behaviour of models of species abundance, the behaviour of linear quantile regressions, the regional distribution of different entities and the temporal change of that, and also the different biotic and abiotic effects on population dynamics.

**Acknowledgements.** We thank deceased Prof. Zsolt Harnos academian for the possibility that the “Adaptation to Climate Change” Research Group of the Hungarian Academy of Sciences provided a background for finishing our job. We owe Prof. Zoltán Mészáros thanks for his professional help and constructive judgements. We thank the Forestry Scientific Institute and its research workers that they made available for us the Lepidoptera data needed for finishing this essay. Our research was supported by the research proposal OTKA TS 049875 (Hungarian Scientific Research Fund); the VAHAVA project; the KLIMA-KKT project (National Office for Research and Technology, Ányos Jedlik Programme); the Research Assistant Fellowship Support (Corvinus University of Budapest); the “Bolyai János” Research Fellowship (Hungarian Academy of Sciences, Council of Doctors) and the TÁMOP project 4.2.1/B-09/1/KMR/-2010-0005.

## REFERENCES

- [1] Ábrahám, G., Tóth, M. (1989): A káposzta-bagolylepke (*Mamestra brassicae* L.) rajzásdinamikai vizsgálata szexferomon-, illat- és fénycsapdával. – *Növényvédelem* 23(3): 119-122.
- [2] Arnan, X., Gracia, M., Comas, L., Retana, J. (2009): Forest management conditioning ground ant community structure and composition in temperate conifer forests in the Pyrenees Mountains. – *Forest Ecology and Management* 258: 51-59.
- [3] Balog, A., Marko, V., Adam, L. (2008): Rove beetles (Coleoptera: Staphylinidae) collected during the long term ecological research in a Hungarian oak forest. – *Journal of Environmental Biology* 29: 263-266.
- [4] Bogdanova, G., Georgieva, T. (2008): Using error-correcting dependencies for collaborative filtering. – *Data & Knowledge Engineering* 66: 402-413.
- [5] Böhlen, M. (2003): 3D visual data mining—goals and experiences. – *Computational Statistics & Data Analysis* 43: 445-469.
- [6] Caldas, A. (1992): Mortality of *Anaea ryphea* (Lepidoptera: Nymphalidae) Immatures in Panama. – *Journal of Research on the Lepidoptera* 31(3-4): 195-204.
- [7] Chefaoui, R.M., Lobo, J.M. (2008): Assessing the effects of pseudo-absences on predictive distribution model performance. – *Ecological Modelling* 210: 478-486.
- [8] Conrad, K.F., Warren, M.S., Fox, R., Parsons, M.S., Woiwod, I.P. (2006): Rapid declines of common, widespread British moths provide evidence of an insect biodiversity crisis. – *Biological Conservation* 132: 279-291.
- [9] Dewar, R.C., Porté, A. (2008): Statistical mechanics unifies different ecological patterns. – *Journal of Theoretical Biology* 251: 389-403.
- [10] Fan, B. (2009): A hybrid spatial data clustering method for site selection: The data driven approach of GIS mining. – *Expert Systems with Applications* 36: 3923-3936.
- [11] Gimesi, L. (2004). Mesterséges intelligencia alkalmazása a rekultivációban. – *Acta Agraria Kaposváriensis* 8(3): 1-9.
- [12] Gimesi, L. (2008): The use of 3-dimensional graphic display method for presenting the changes in weather. – *Applied Ecology And Environmental Research* 6(1): 165-176.
- [13] Gimesi, L. (2009): Development of a visualization method suitable to present the tendencies of the changes in precipitation. – *Journal of Hydrology* 377: 185-190.

- [14] Gray, J., Chaudhuri, S., Bosworth, A., Layman, A., Reichart, D., Venkatrao, M., Pellow, F., Pirahesh, H. (1997): Data Cube: A Relational Aggregation Operator Generalizing Group-By, Cross-Tab, and Sub-Totals. – Microsoft Corporation, Data Mining and Knowledge Discovery 1: 29-54.
- [15] Han, J., Kamber, M. (2004): Adatbányászat – Konceptiók és technikák. – Panem, Budapest.
- [16] Heuvelink, G.B.M., Webster, R. (2001): Modelling soil variation: past, present, and future. – Geoderma 100: 269-301.
- [17] Hufnagel, L., Sipkay, Cs., Drégely-Kis, Á., Farkas, E., Türei, D., Gergócs, V., Petrányi, G., Baksa, A., Gimesi, L., Eppich, B., Dede, L., Horváth, L. (2008): Klímaváltozás, biodiverzitás és ökoszisztémakörnyezeti folyamatok kölcsönhatásai. – In: Harnos, Zs., Csete, L. (ed.): Klímaváltozás: Környezet – Kockázat – Társadalom. Szaktudás Kiadó Ház, Budapest, 229-266.
- [18] Ibáñez, J.J., De-Alba, S., Bermúdez, F.F., García-Álvarez, A. (1995): Pedodiversity: concepts and measures. – Catena 24: 215-232.
- [19] Izsák, J. (1994): Applying the jackknife method to significance tests of diagnostic diversity. – Methods of Information in Medicine 33: 214-219.
- [20] Izsák, J., Juhász-Nagy, P. (1984): Studies of diversity indices on mortality statistics. – Annales Univ. Sci. Budapestiensis, Sectio Biologica 24-26: 11-27.
- [21] Jermy, T. (1961): Kártevő rovarok rajzásának vizsgálata fénycsapdával. – A Növényvédelem Időszervi Kérdései 2: 53-61.
- [22] Keim, D.A. (2004): Pixel based visual data mining of geo-spatial data. – Computers & Graphics 28: 327-344.
- [23] Kennedy, R.I., Kee, Y., Van Roy, B., Reed, C.D., Lippman, R.P. (1998): Solving Data Mining Problems Through Pattern Recognition. – Upper Saddle River, Prentice Hall.
- [24] Kevan, P.G. (1999): Pollinators as bioindicators of the state of the environment: species, activity and diversity. Agriculture, Ecosystems and Environment 74: 373-393.
- [25] Kimura, G., Inoue, E., Hirabayashi, K. (2008): Seasonal abundance of adult caddisfly (Trichoptera) in the middle reaches of the Shinano River in Central Japan. – 6<sup>th</sup> International Conference on Urban Pests, Budapest.
- [26] Leskó, K., Szentkirályi, F., Kádár, F. (1997): A gyűrűsszövő (*Malacosoma neustria* L.) hosszútávú (1962-1996) populációingadozásai Magyarországon. – Erdészeti Kutatások 86-87: 207-220.
- [27] Marchiori, M.O., Romanowski, H.P. (2006): Species composition and diel variation of a butterfly taxocene (Lepidoptera, Papilionoidea and Hesperioidea) in a restinga forest at Itapuã State Park, Rio Grande do Sul, Brazil. – Revista Brasileira de Zoologia 23(2): 443-454.
- [28] Menhinick, E.F. (1962): Comparison of invertebrate populations of soil and litter of mowed grasslands in areas treated and untreated with pesticides. – Ecology 43: 556-561.
- [29] Mészáros, Z. (1993): Bagolylepkek – Noctuidae. – In: Jermy, T., Balázs, K. (1993): A növényvédelmi állattan kézikönyve 4/B: 453-831.
- [30] Mishra, A.K., Özger, M., Singh, V.P. (2009): An entropy-based investigation into the variability of precipitation. – Journal of Hydrology 370: 139-154.
- [31] Moon, Y., Kim, J. (2007): Efficient moving average transform-based subsequence matching algorithms in time-series databases. – Information Sciences 177: 5415-5431.
- [32] Mulligan, M. (1998): Modelling the geomorphological impact of climatic variability and extreme events in a semi-arid environment. – Geomorphology 24: 59-78.
- [33] Nowinszky, L. (2003a): A fénycsapdázás kezdete és jelenlegi helyzete. – In: Nowinszky, L. (ed.) A fénycsapdázás Kézikönyve, Savaria University Press, Szombathely.
- [34] Nowinszky, L. (2003b): A fénycsapdás gyűjtési adatok hasznosítása. – In: Nowinszky, L. (ed.) A fénycsapdázás Kézikönyve, Savaria University Press, Szombathely.
- [35] Nowinszky, L. (2003c): A fénycsapdás gyűjtési adatok feldolgozási módszerei. – In: Nowinszky, L. (ed.) A fénycsapdázás Kézikönyve, Savaria Univ. Press, Szombathely.



- [36] Pyle, D. (1999): *Data Preparation for Data Mining*. – Morgan Kaufmann, San Francisco.
- [37] Sipkay, Cs., Hufnagel, L., Gaál, M. (2005): Zoocenological state of microhabitats and its seasonal dynamics in an aquatic macroinvertebrate assembly (hydrobiological case studies on Lake Balaton, №. 1). – *Applied Ecology and Environmental Research* 3(2): 107-137.
- [38] Skalskia, T., Pošpiech N. (2006): Beetles community structures under different reclamation practices. – *European Journal of Soil Biology* 42: 316-320.
- [39] Szentkirályi, F. (1984): Analysis of light trap catches of green and brown lacewings (Nouropteroidea: Planipennia, Chrysopidae, Hemerobiidae) in Hungary. – *SIEEC X*. Budapest, 177-180.
- [40] Szentkirályi, F. (2002): Fifty-year-long insect survey in Hungary: T. Jermy's contributions to light trapping. – *Acta Zoologica Academiae Scientiarum Hungaricae* 48(1): 85-105.
- [41] Szentkirályi, F., Szalay, K., Kádár, F. (1995): Jeleznek-e klímaváltozást a fénycsapdás rovargyűjtések? – *Erdő és Klíma Konferencia, Noszvaj 1994*: 171-177.
- [42] Szontagh, P. (1975): A fénycsapda hálózat szerepe az erdészeti kártevők prognózisában. – *Növényvédelem* 11: 54-57.
- [43] Szontagh, P. (2001): Rovarok okozta problémák és kihívások erdeinkben. – *Erdészeti Tudományos Intézet Kiadványai* 15: 35-37.
- [44] Tóthmérész, B. (1997): *Diverzitási rendezések*. – Scientia, Budapest
- [45] Tóthmérész, B. (2001): Kvantitatív ökológiai kutatások különös tekintettel a skálázási és mintázati problémákra. – In: Borhidi, A. (2001): *Ökológia az ezredfordulón*, Budapest, Akadémiai Kiadó, 15-25.
- [46] Tóthmérész, B. (2002): A diverzitás jellemzésére szolgáló módszerek evolúciója. – In: Salamon-Albert, É. (2002): *Magyar botanikai kutatások az ezredfordulón*.
- [47] Wolda, H., O'Brien, C.W., Stockwell, H.P. (1998): *Weevil Diversity and Seasonally in Tropical Panama as Deduced from Light trap Catches (Coleoptera: Curculionioidea)*. – Smithsonian Institution Press, Washington, D.C.